



An Enhanced Accuracy High Readability VTVM

IN MOST electronics laboratories there is a small but continuing requirement for measuring a-c voltages to the best possible accuracy. This requirement is generally not met by laboratory standard voltmeters, either because their resistance is too low or because the frequency of the voltage to be measured is outside their limited range. While the popular -hp- Model 400D VTVM with its 2% accuracy from 20 cps to 1 mc meets many of these requirements, there are occasions where even higher accuracy is desired.

SEE ALSO:
"Use of Notch
Wattmeter", p. 3

The enhanced accuracy vacuum-tube voltmeter shown in Fig. 1 has been designed for use in such applications. This instrument measures a-c voltages to an accuracy of within $\pm 1\%$



Fig. 1. New -hp- Model 400H VTVM has 1% accuracy over 50 cps-500 kc range, 2% accuracy over 20 cps-1 mc range, is usable to 4 mc. Mirror scale and high-definition meter contribute to accuracy of reading.

over the frequency range from 50 cps to 500 kc and over the voltage range from 1 millivolt full scale to 300 volts full scale in 12 ranges. Further, this 1% tolerance applies for any power line voltage from 103 to 127 volts. The instrument has a very high input impedance of 10 megohms* shunted by 25 mmf on the low ranges or by 15 mmf on the high ranges. Circuit loading by the voltmeter is thus minimized. The instrument can also be used over the frequency range from 10 cps to 4 megacycles at an accuracy of within $\pm 5\%$.

The problem of designing a vacuum tube voltmeter with 1% accuracy over a wide frequency and line voltage range can be divided into two principal parts. First, a high-gain, wide-range amplifier with a stability sufficient to support this accuracy must be designed. Designing such an amplifier so that it can be manufactured within accepted economic limits is a major design problem.

The second principal part of the voltmeter design is the indicating meter itself. For use in a 1%-accuracy voltmeter, the indicating meter must have considerably less than 1% error and considerably higher than 1% readability.

As to the first part of the problem—the high-stability amplifier—it was found possible to use the same basic amplifier used in the -hp- Model 400D VTVM†. The amplifier in that instrument was a new type of design which offered very desirable characteristics. For one thing, the amplifier had a mid-band feedback of

*low-frequency real component.

†John Zevenbergen, "Wider Range and Higher Stability in the New -hp- 4 MC Voltmeter," Hewlett-Packard Journal, Vol. 5, No. 9, May, 1954.

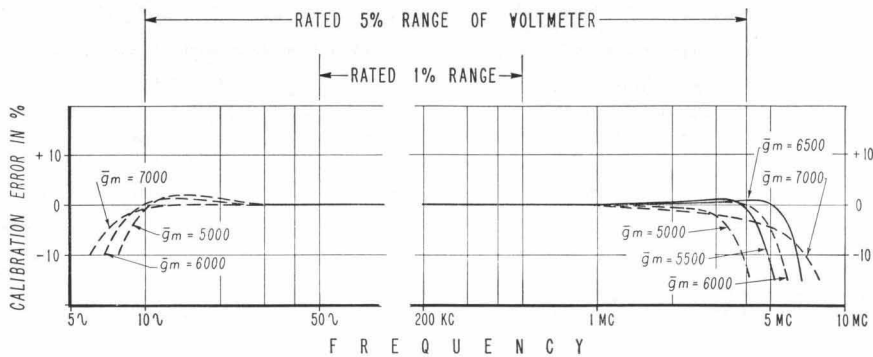

Fig. 2. Effect on voltmeter reading of variation in G_m in all tubes of Model 400H amplifier. Center G_m value for tubes used is 6200 micromhos.

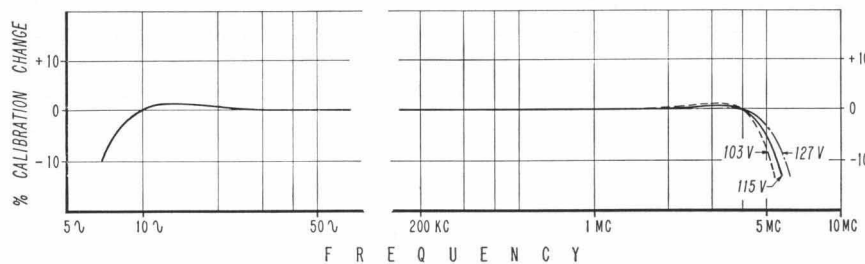

Fig. 3. Effect on voltmeter reading of $\pm 10\%$ line voltage variation.

nearly 60 db. A 2.5:1 change in the effective G_m of the amplifier would thus result in less than 0.2% change in the mid-band amplifier gain.

In other words, the G_m of all of the amplifier tubes could each vary 20% below or above rated value for their type before a discernible change occurs in mid-band gain. Even at the ends of the 4 megacycle range of the amplifier, large G_m variations produce only a minor change in gain (Fig. 2). This high order of insensitivity to tube G_m virtually insures the instrument against line voltage problems (Fig. 3) or tube replacement effects on the mid-band calibration. Obviously, then, this amplifier more than safely gives the required stability, having much less than 1% gain variation for a wide range of tube G_m 's and for a wide range of line voltages over the middle 50 cps-500 kc frequency range and, in addition, can be used with good accuracy over much wider ranges.

METER

The need for the indicating meter itself to contribute less than 1% error

to the measurement formed the basis for selecting a $\frac{1}{2}\%$ accuracy meter for the instrument. To insure a good order of readability for the indicating meter, a 5-inch movement was selected. The meter is provided with

a mirror scale and knife-edge pointer to minimize parallax errors. The 5-inch meter permits a scale with 100 divisions to be used for the "1" range in place of the usual 50-division scale. The "3" range has a 60-division scale, also twice as many divisions as usual. The meter face is reproduced two-thirds of actual size in Fig. 4 where the high order of definition is apparent.

GENERAL

In other respects the new voltmeter incorporates all of the popular features of the other *-hp-* voltmeters. The meter face includes a DB scale calibrated with 0 dbm equal to 1 milliwatt in 600 ohms. This scale, in combination with the 10 db interval for the range switch steps, permits the instrument to make direct db readings over a range from -72 to +52 dbm. Terminals are provided to permit the instrument to be used as a stable, wide-range amplifier. The cabinet is arranged with a bail to permit the meter to be tilted for easier viewing in bench set-ups.

—John Zevenbergen

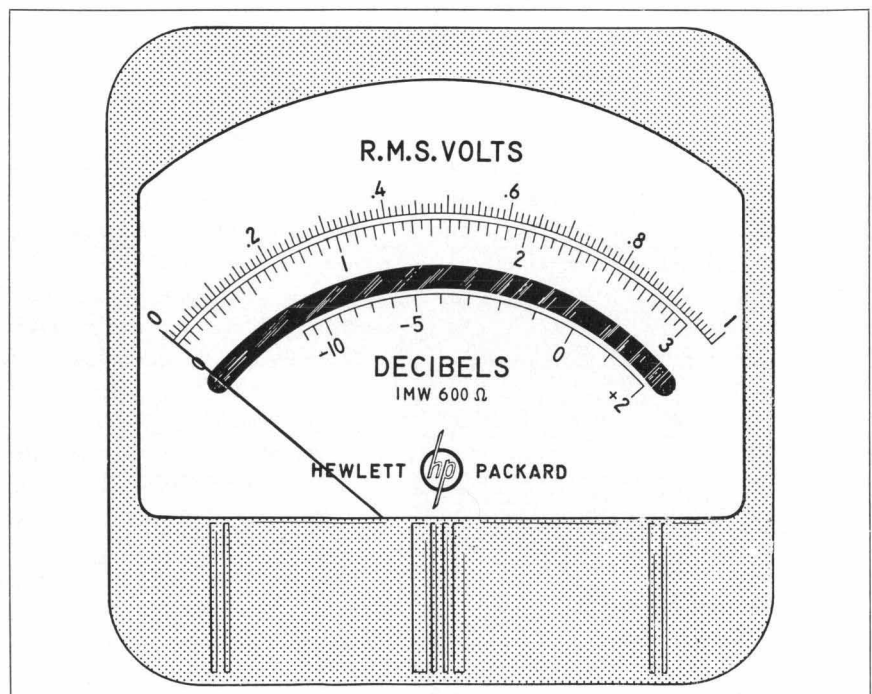

Fig. 4. Two-thirds size reproduction of meter used in Model 400H. Upper scale is calibrated in 1% increments, "3" scale in 1.7% increments.

VOLTAGE RANGE: 0.1 millivolts to 300 volts. 12 ranges, selected with front panel switch. Full scale readings of 0.001, 0.003, 0.010, 0.030, 0.100, 0.300, 1.0, 3.0, 10.0, 30, 100, 300 volts.

FREQUENCY RANGE: 10 cps to 4 megacycles.

ACCURACY: With line voltages of nominal voltage $\pm 10\%$ (103 volts to 127 volts), overall accuracy is: within $\pm 1\%$ of full scale value, 50 cps to 500 kc; within $\pm 2\%$ of full scale value, 20 cps to 1 mc; within $\pm 5\%$ of full scale value, 10 cps to 4 mc.

LONG TERM STABILITY: Reduction in G_m of amplifier tubes to 75% of nominal value results in error of less than 0.5%, 20 cps to 1 mc.

CALIBRATION: Reads rms value of sine wave. Voltage indication proportional to average value of applied wave. Linear

SPECIFICATIONS

-hp- MODEL 400H HIGH ACCURACY VACUUM-TUBE VOLTMETER

voltage scales, 0 to 3 and 0 to 1.0; db scale, -12 db to +2 db, based on 0 dbm = 1 mw in 600 ohms, 10 db intervals between ranges.

INPUT IMPEDANCE: 10 megohms shunted by 15 μf on ranges 1.0 volt to 300 volts; 25 μf on ranges 0.001 volt to 0.3 volt.

AMPLIFIER: Output terminals are provided so voltmeter can be used to amplify small signals or to monitor waveforms under test with an oscilloscope. Output approximately 0.15 volts rms on all ranges with full scale meter deflection. Amplifier fre-

quency response same as that of voltmeter. Internal impedance approximately 50 ohms over entire frequency range.

POWER SUPPLY: 115/230 volts $\pm 10\%$, 50/1,000 cps, approx. 100 watts.

SIZE: Cabinet Mount: 11 $\frac{1}{2}$ " high, 7 $\frac{1}{2}$ " wide, 11 $\frac{3}{4}$ " deep. Rack Mount: 19" high, 7" wide, 12" deep.

WEIGHT: Cabinet Mount: 18 lbs.; shipping weight approximately 32 lbs. Rack Mount: 22 lbs.; shipping weight approximately 35 lbs.

PRICE: Model 400H High Accuracy Vacuum Tube Voltmeter, Cabinet Mount, \$325.00 f.o.b. Palo Alto, California. Model 400HR High Accuracy Vacuum Tube Voltmeter, Rack Mount, \$330.00 f.o.b. Palo Alto, California.

Data subject to change without notice.

USE OF THE "NOTCH WATTMETER" WITH -hp- SIGNAL GENERATORS

One of the systems for measuring the peak power of r-f pulses is the "notch wattmeter." This system is useful in many high-frequency measurement applications where the average power in a pulsed r-f wave is too low to be measured directly by a power meter. The r-f pulse may be the low-level output from a monitoring terminal on a high-power pulse transmitter or it may be that available from a laboratory setup. The peak power in these applications is usually in the milliwatt region while the average power is in the tens of microwatts region.

The basis of operation of the system is to compare the amplitude of the r-f pulse to be measured, such as that in Fig. 1(a), with the amplitude of a pulsed-off r-f wave, such as that in Fig. 1(b), which is obtained from

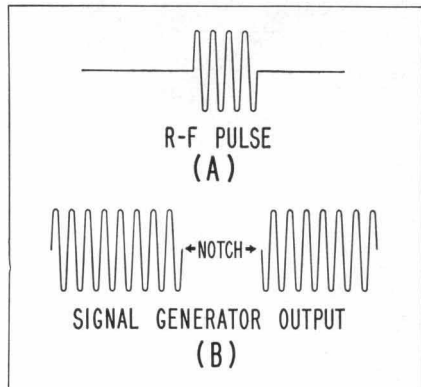

Fig. 1. Sketch illustrating (a) typical r-f pulse to be measured; (b) pulse-off type output required from signal generator.

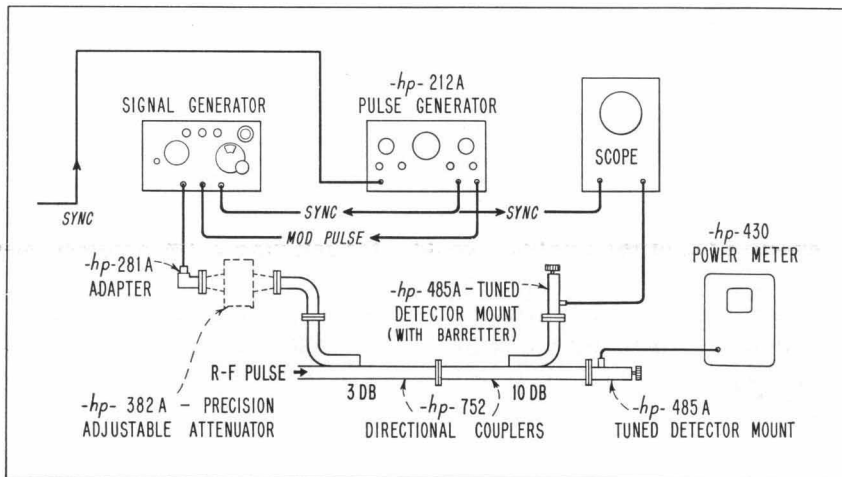

Fig. 2. Typical equipment arrangement for forming notch wattmeter at X-band frequencies.

a signal generator. When the signal generator power has been adjusted to be equal to the peak power of the pulse under measurement, the peak power of the pulse can be determined in two ways. First, it can be determined from the calibrated output attenuator on the signal generator, or second, it can be determined from the reading of a power meter to which the two signals are simultaneously applied. The second method is generally preferable from an overall accuracy standpoint.

Fig. 2 shows a typical arrangement for measuring power with the "notch" system at microwave frequencies. The two r-f powers are combined in a wave guide directional coupler and applied to the power

meter. A second directional coupler is used to split off some of the power for monitoring by an oscilloscope. In operation the pulse width, repetition frequency and delay controls on the modulating pulse generator are adjusted so that the "off" time of the signal generator is coincident with the pulse being measured. The signal generator r-f frequency is made very nearly the same as that of the wave under measurement to avoid frequency effects in the crystal detector.

When the pulses have been brought into coincidence, the signal generator power should be adjusted to be equal to the peak power of the pulse being measured by making the height of the two pulses exactly

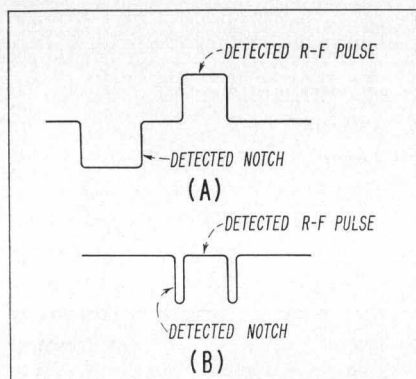

Fig. 3. Oscilloscope display (a) when pulses are not coincident and (b) when pulses are coincident and of equal amplitude.

equal. When the signal generator off time is slightly longer than the length of the pulse being measured and the pulse heights are equal, the presentation will be similar to Fig. 3(b). With low duty cycles it is relatively unimportant that the off time be precisely equal to the pulse time.

For the coupling values of the directional couplers, it is convenient to use the values specified in Fig. 2. With this arrangement peak powers down to between -15 and -20 dbm can be measured. In marginal cases a few db can be gained by using a 10 db coupler in the first location as well as the second. A tuned detector mount is also required in the lower power cases to obtain a usable voltage to drive the oscilloscope. The oscilloscope should be a high-gain type.

Using the setup of Fig. 2, the reading of the power meter should be compensated by adding 11% or 1 db to the observed value. This step compensates for the power split off by the 10 db second coupler. If the first coupler is a 3 db coupler, the power split off by it must be corrected for by adding 3 db to the previously corrected meter reading. One db should be added if a 10 db first coupler is used.

PULSE-OFF MODULATION

It will be noted that the notch wattmeter system requires that the signal generator be turned off rather than on by the modulating pulse.

This type of modulation is the inverse of that which most generators are designed to produce. It so happens, however, that most of the *-hp-* microwave generators can be modulated off by the *-hp-* 212A Pulse Generator using only the existing modulation terminals and controls on the signal generators.

The usual condition wherein pulse-off modulation can be obtained with *-hp-* microwave generators is when a positive pulse is applied to the modulation input terminal of the generator while the generator's modulation selector switch is in the external f-m position. What happens circuit-wise under these circumstances is shown in Fig. 4. Fig. 4(a) is a single-frequency power output vs. repeller voltage curve which represents a typical oscillation mode of the klystrons used in the *-hp-* microwave generators. The dashed line in the characteristic is the typical value to which the repeller voltage of the klystron is maintained by the voltage-tracking system of the generator.

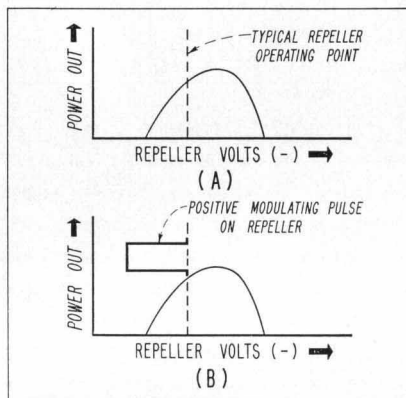

Fig. 4. (a) Typical power output vs. repeller voltage characteristic of klystron used in *-hp-* microwave generators. (b) Positive modulating pulse applied to repeller circuit pulses klystron out of oscillation.

Fig. 4(b) shows the effect of applying a positive pulse to the external modulation terminal of the generator. When the modulation selector switch is in the external f-m position, the pulse is connected to the repeller circuit. If the pulse is of sufficiently large amplitude, it drives

the repeller voltage out of the oscillation mode for the duration of the pulse. This produces the desired off-type modulation.

Pulse-off modulation can be obtained in this manner with the *-hp-* Models 618, 620A, 626A, and 628A generators which collectively operate from 3.8 to 20 kilomegacycles. All of these generators will operate in this manner with the output produced by the *-hp-* 212A Pulse Generator, i.e., 50 volts. A positive modulating pulse is generally preferable for modulating purposes with the Models 618 and 620A, while a negative pulse is generally preferable with the Models 626A and 628A. An opposite polarity pulse may produce superior results, however, in a given generator. Both negative and positive pulses are available from the *-hp-* 212A Pulse Generator.

OTHER GENERATORS

It is also possible to obtain pulse-off modulation with most of the *-hp-* generators that operate at frequencies lower than those listed above. These lower frequency generators fall into two groups. The first group includes the *-hp-* 608 and 612 which can be notch-modulated by applying a negative pulse of about 5 volts amplitude. In the Model 608 this pulse should be applied to the external modulation terminals while the modulation selector switch is set to the external modulation position. In the Model 612 it should be applied to the pulse input connector while the modulation selector switch is set to the *pulse 1* position and the modulation direction switch is set to the *mod. down* position.

The second group includes the *-hp-* Models 614 and 616. In this group, however, notch modulation can only be obtained at high repetition frequencies. A *positive* pulse of 50-70 volts amplitude should be applied to the external modulation connector while the modulation selector switch is in the position specifying an external *negative* pulse.